

Toby 1710

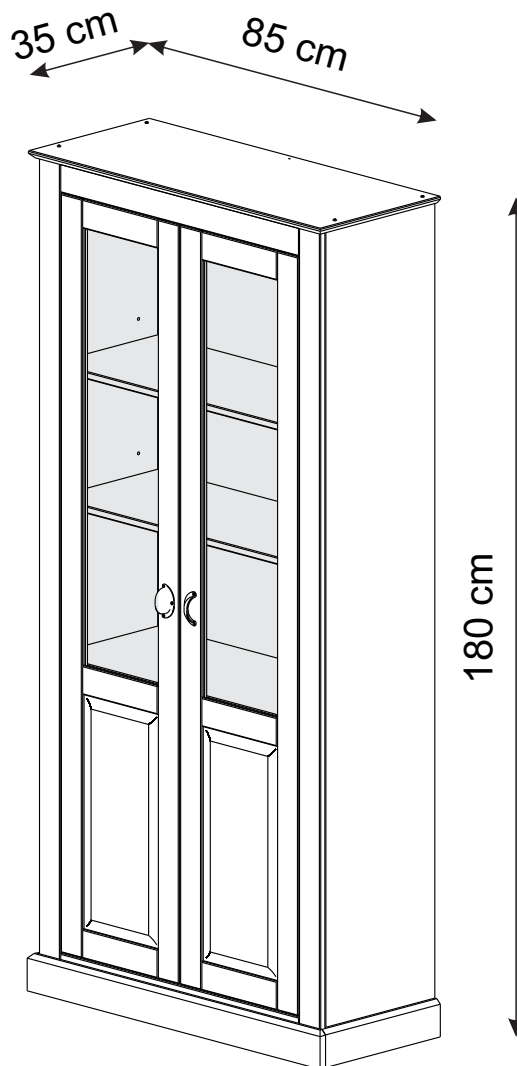

Montageanleitung
1710



Notice de montage
1710



Handleiding voor de montage
1710



Montážní návod
1710



Szerelési útmutató
1710



Montaj talimatı
1710



Assembly instructions
1710



Istruzioni di montaggio
1710



Instrukcja montażu
1710



Návod na montáž
1710



Instrucțiuni de montaj
1710



Инструкция по монтажу
1710

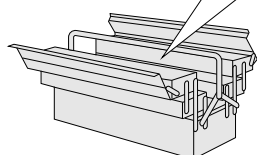
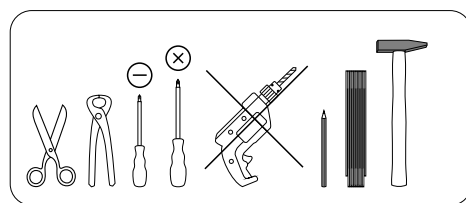
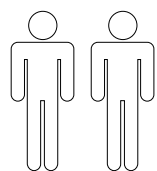

0
10
20
30
40
50
60
70
80
90
100
110
120
130
140
150
160
170
180
190
200

Service • Assistenza • Dienstverlening • Serwis Servis • Szerviz • Сервисная служба	
Name • Nom • Nome • Naam • Nazwa • Jméno • Názov • Név • Denumire • Ísim • Название	
Nr. • No. • N° • Номер • Č • Sz	
Typ • Type • Tip • Típus • Tipo • Тип	

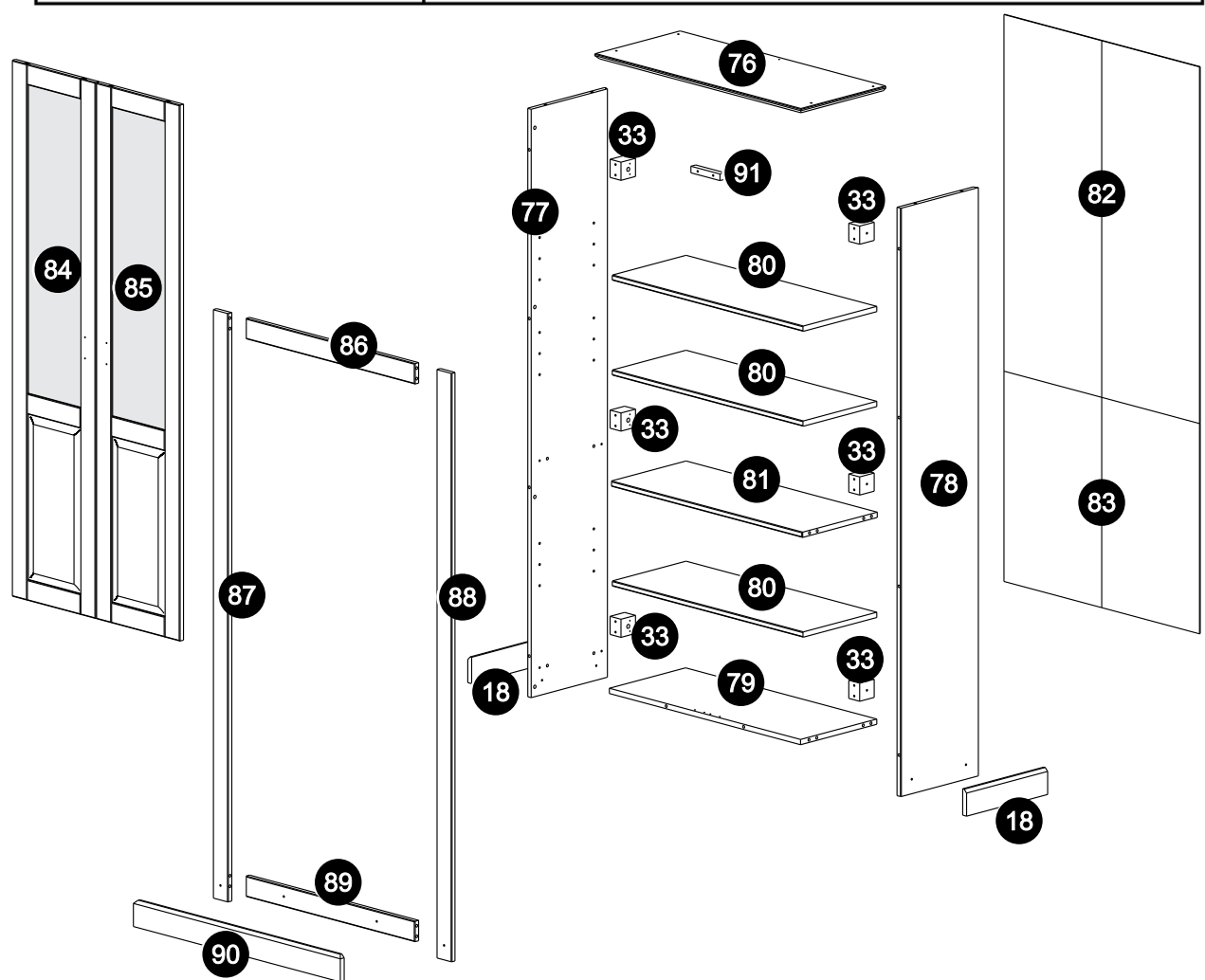

- | | | | | | | | |
|------------------------|-----------------------|------------------------|-----------------------|------------------------|-----------------------|------------------------|-----------------|
| A 8,0x30
30x | B 4,0x30
2x | C 3,5x14
42x | D 4,5x60
1x | E 3,5x25
18x | F 3,0x12
6x | G 4,0x40
22x | H
52x |
| I
8x | J
8x | K
10x | L
2x | M
6x | N
6x | O
1x | P
12x |
| Q
4x | R
4x | | | | | | |

1

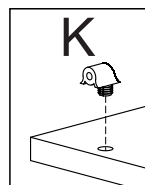
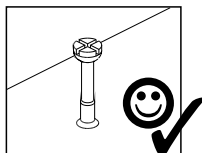
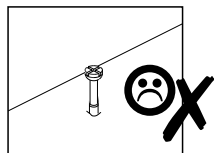
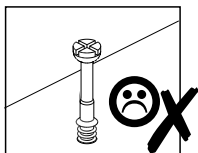
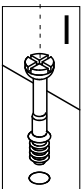
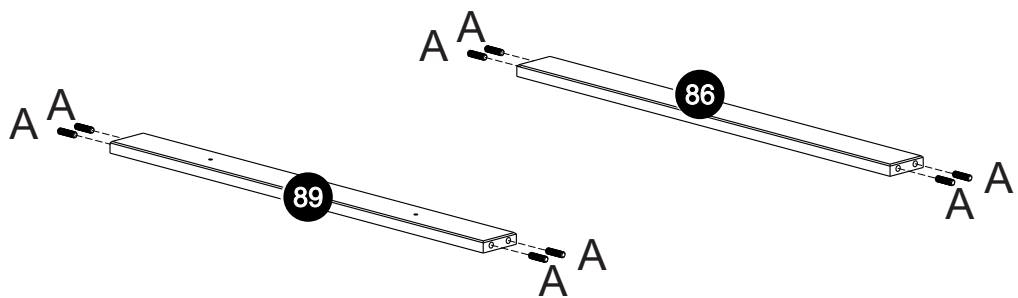
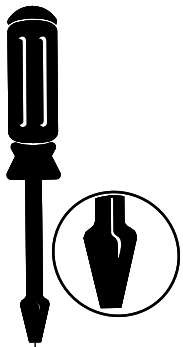
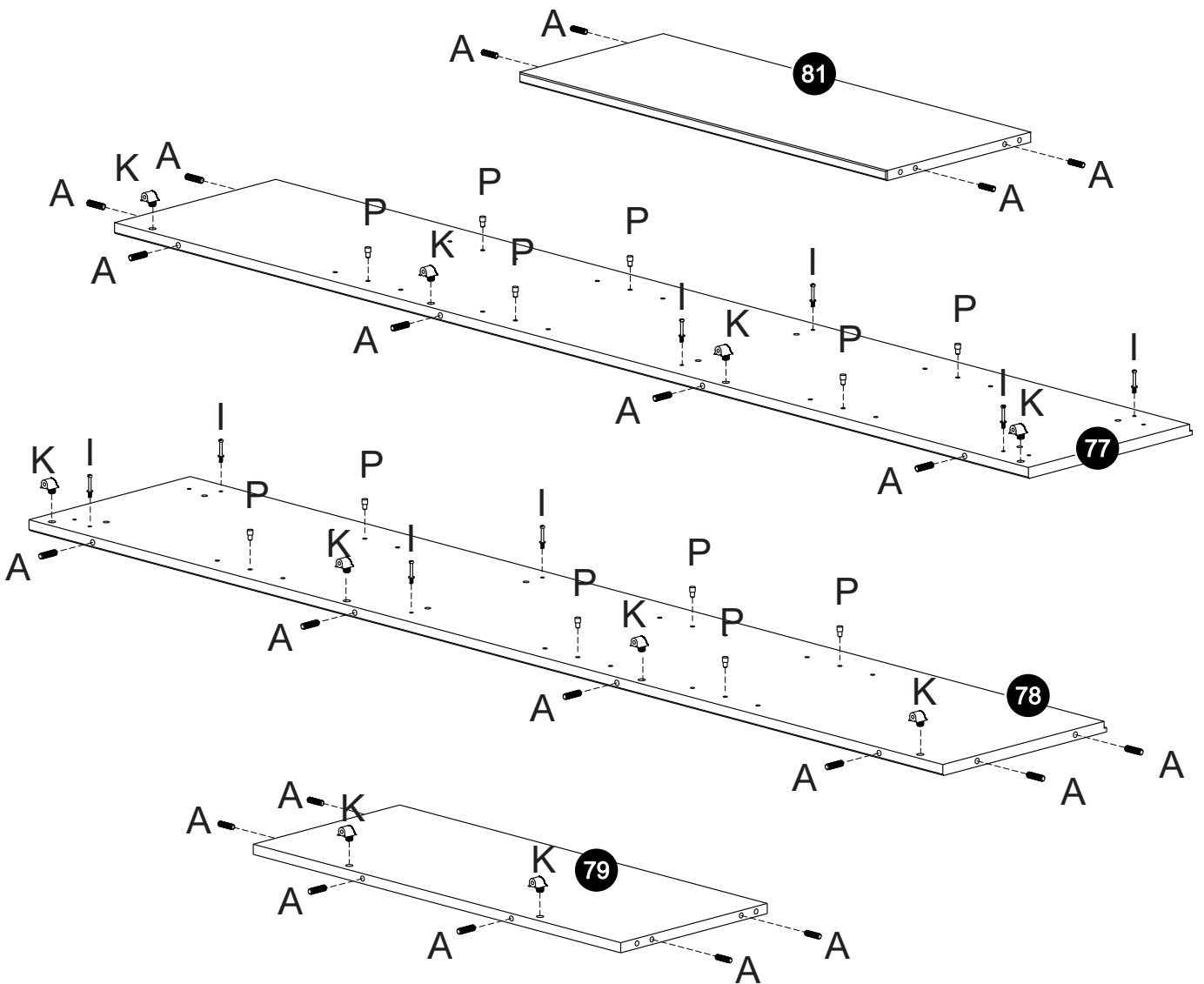
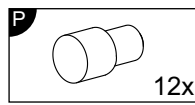
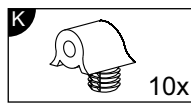
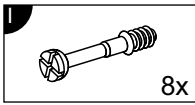
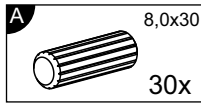

2

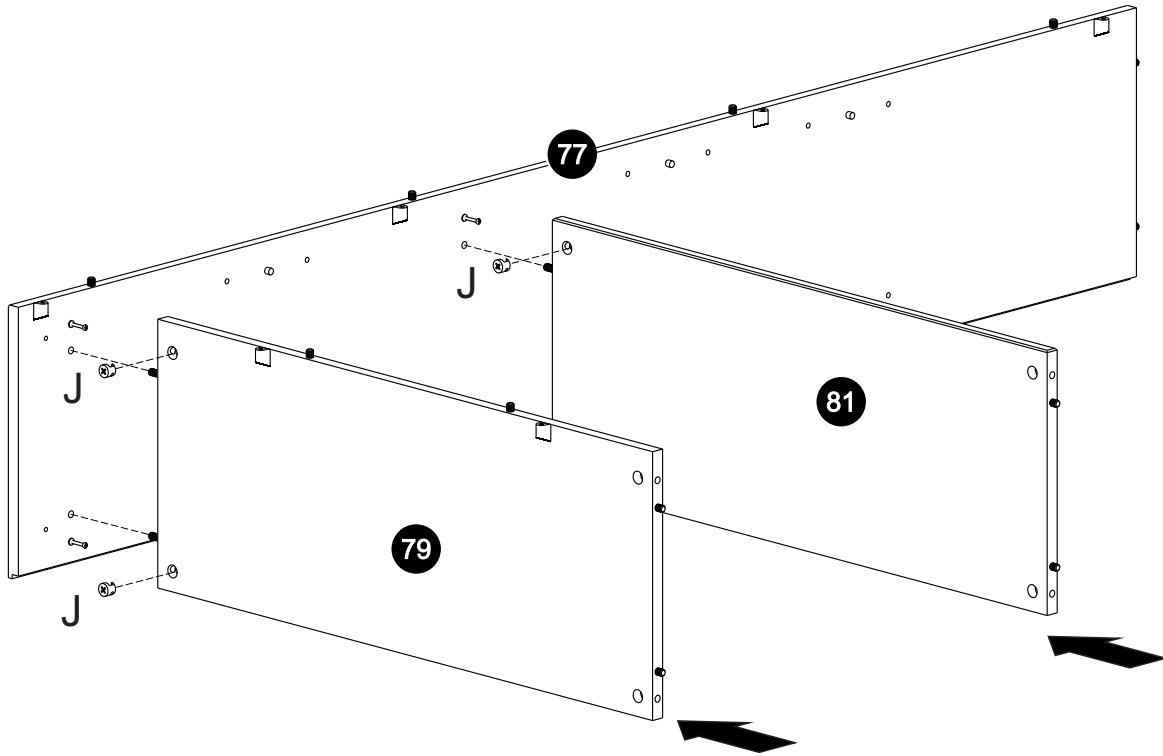
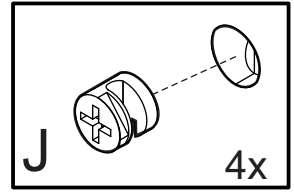
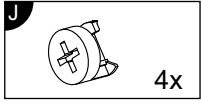

3

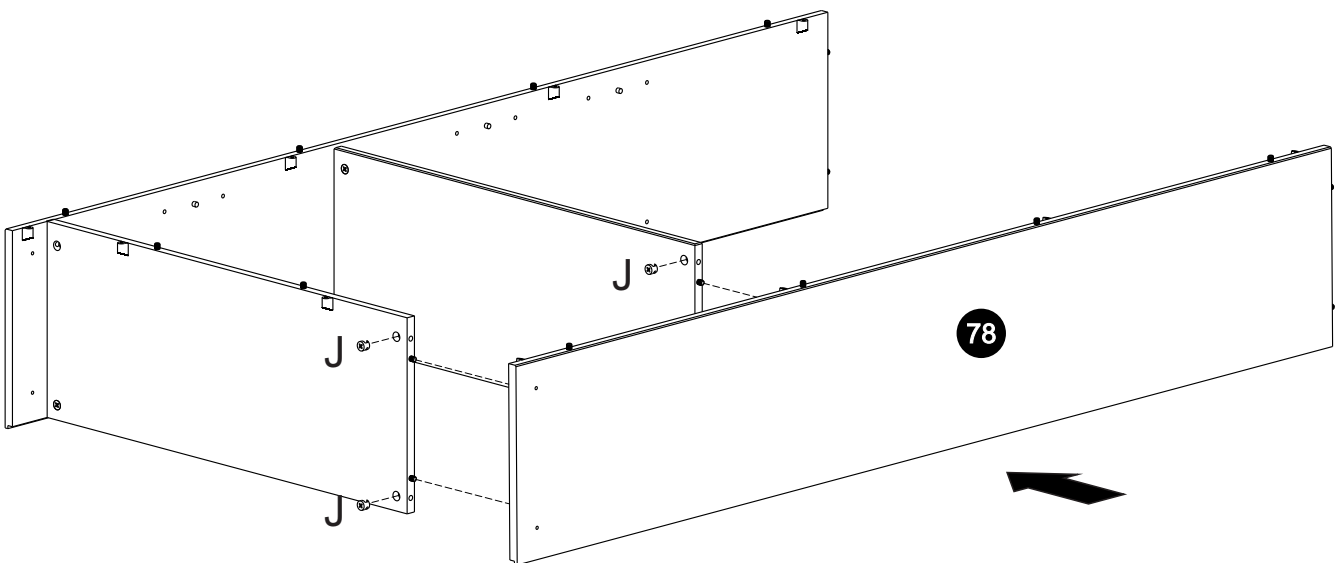
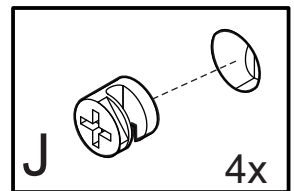
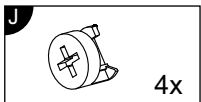

4

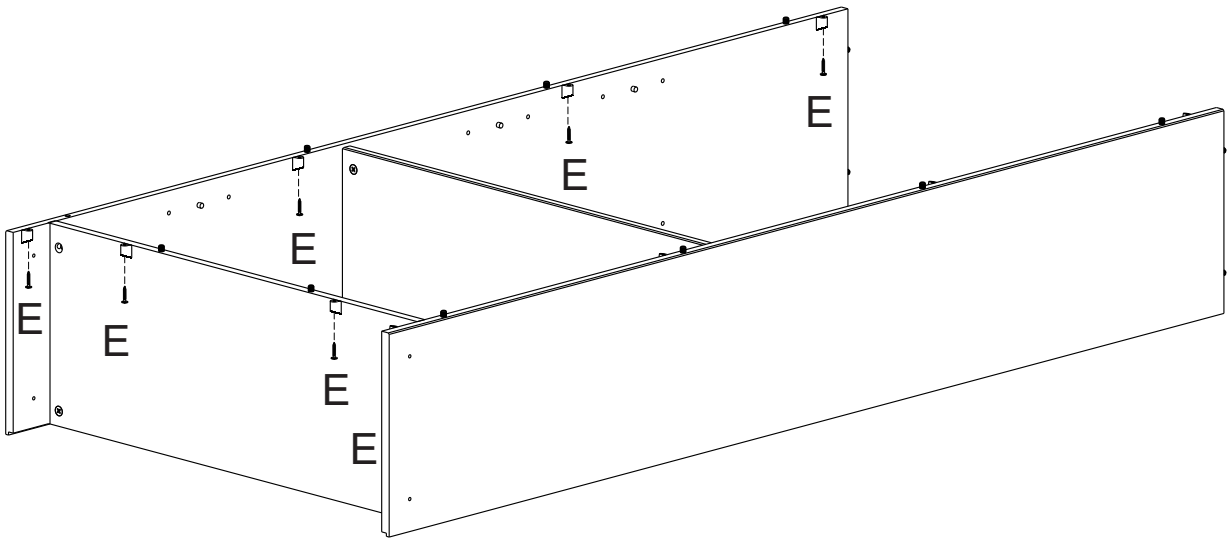
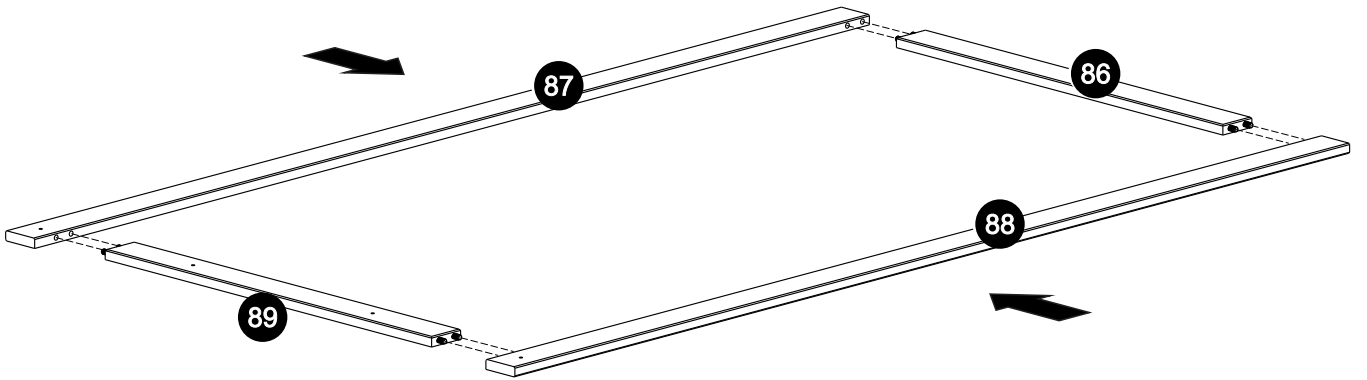
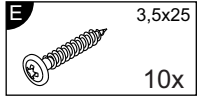

5

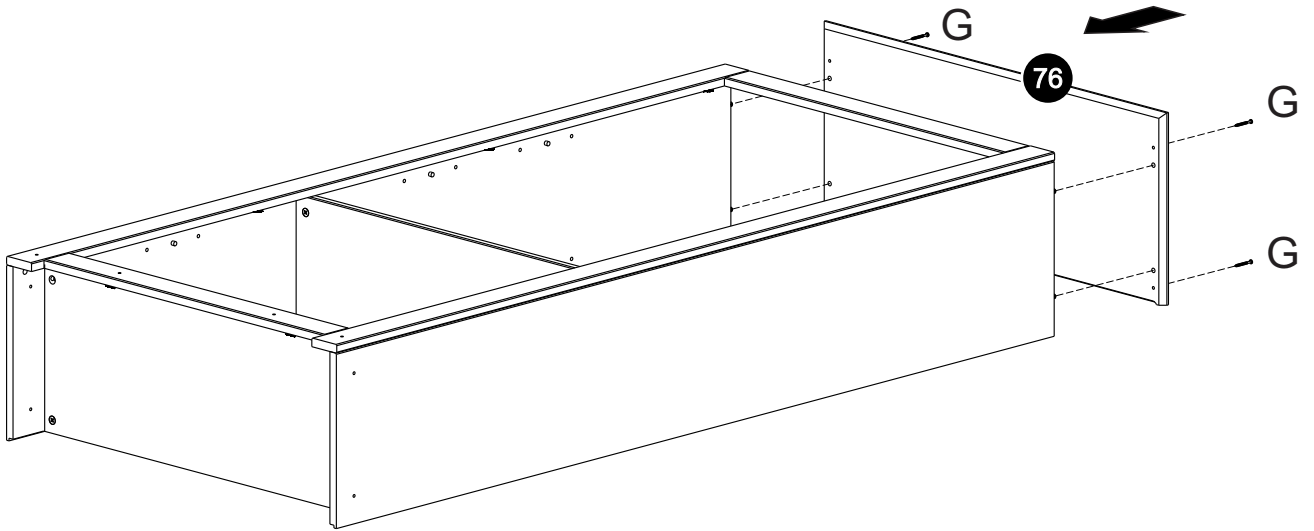
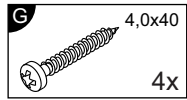

6

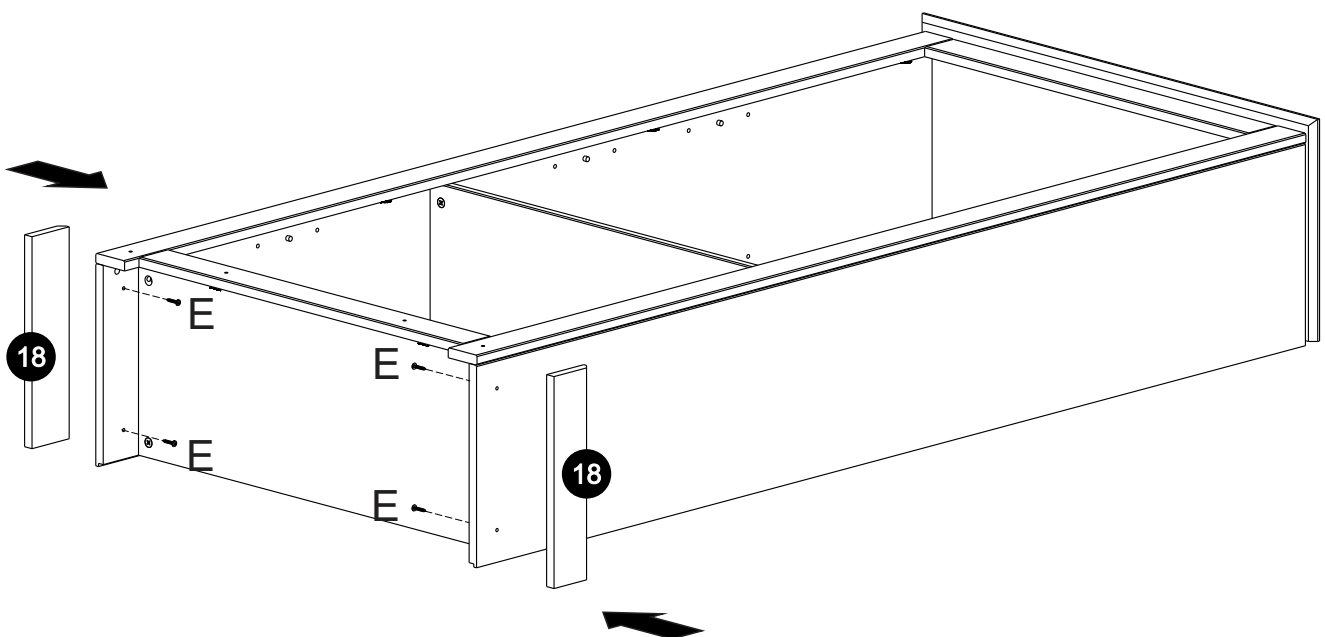
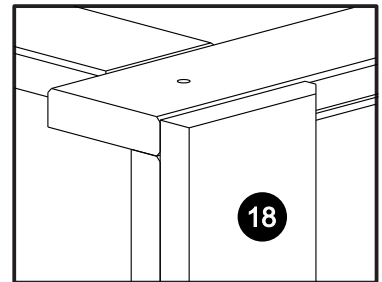
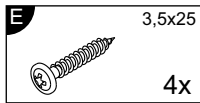

7

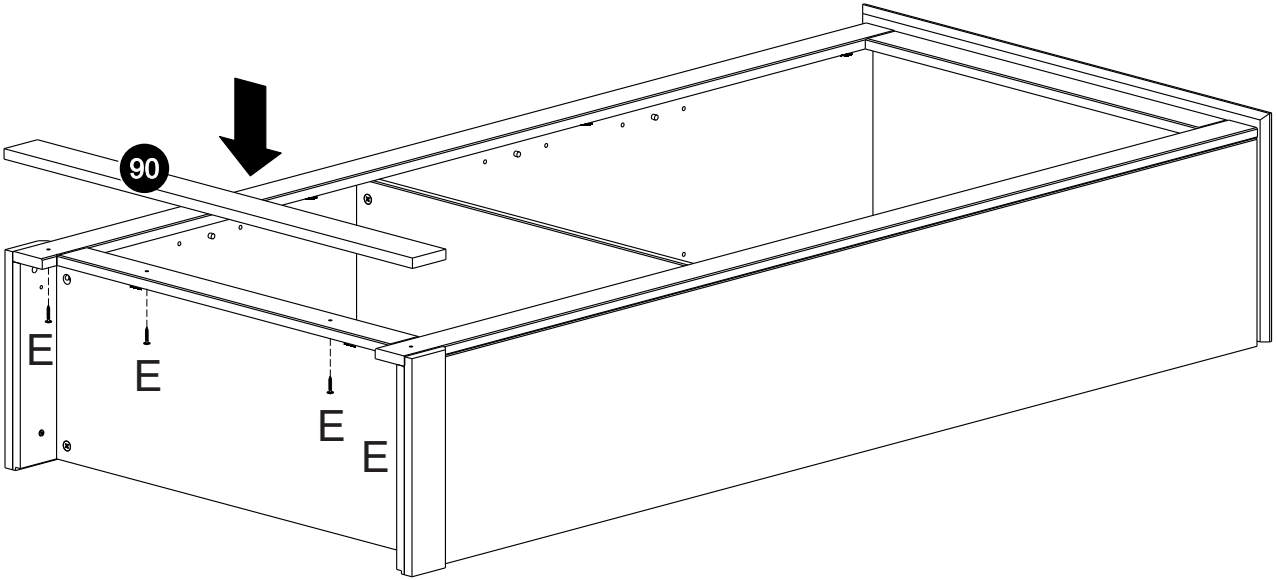
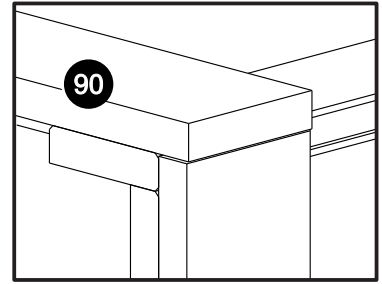
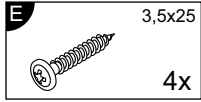

8

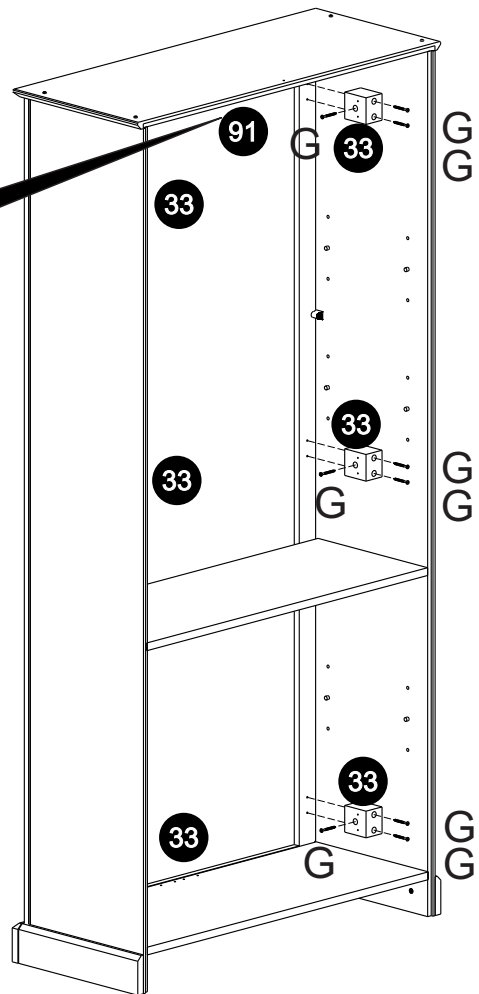
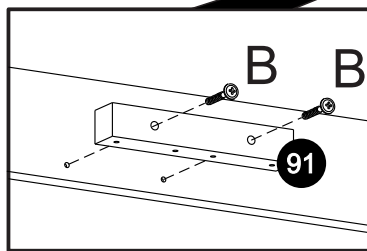
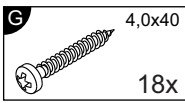
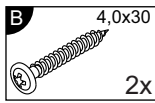

9

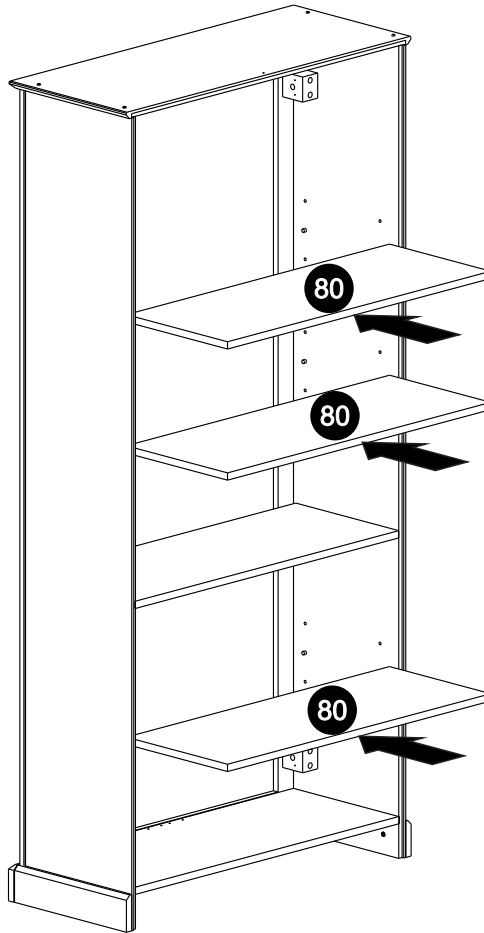

10

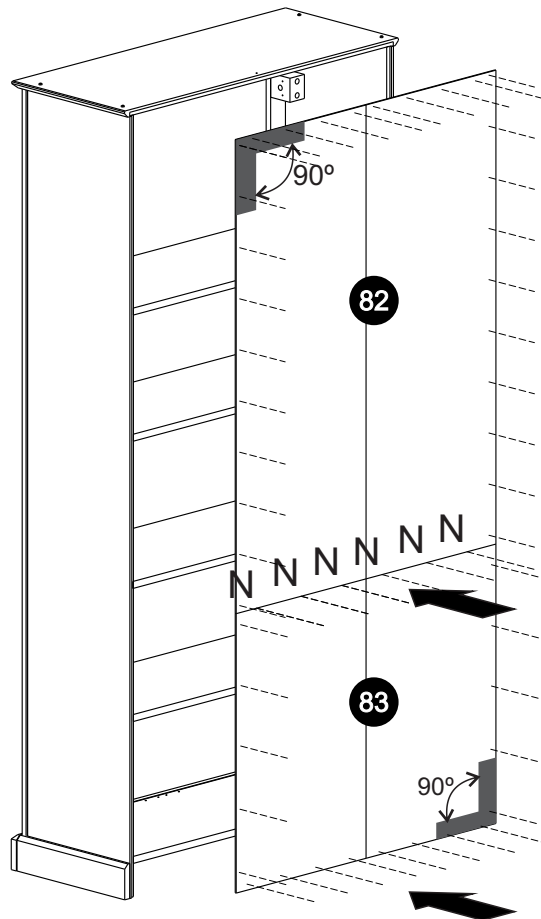
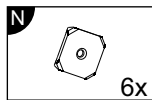
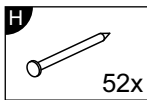

11

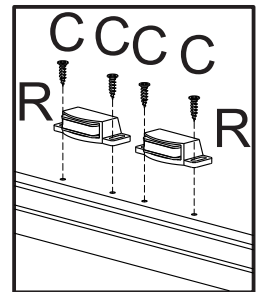
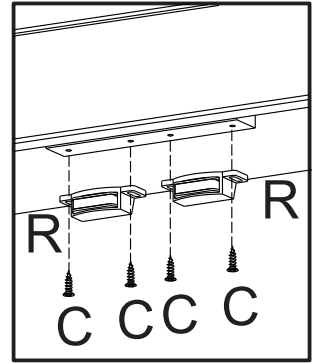
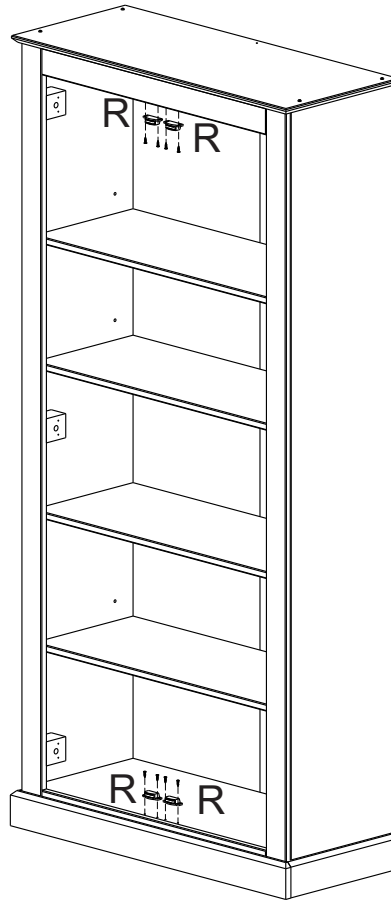
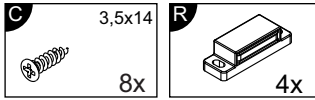

12

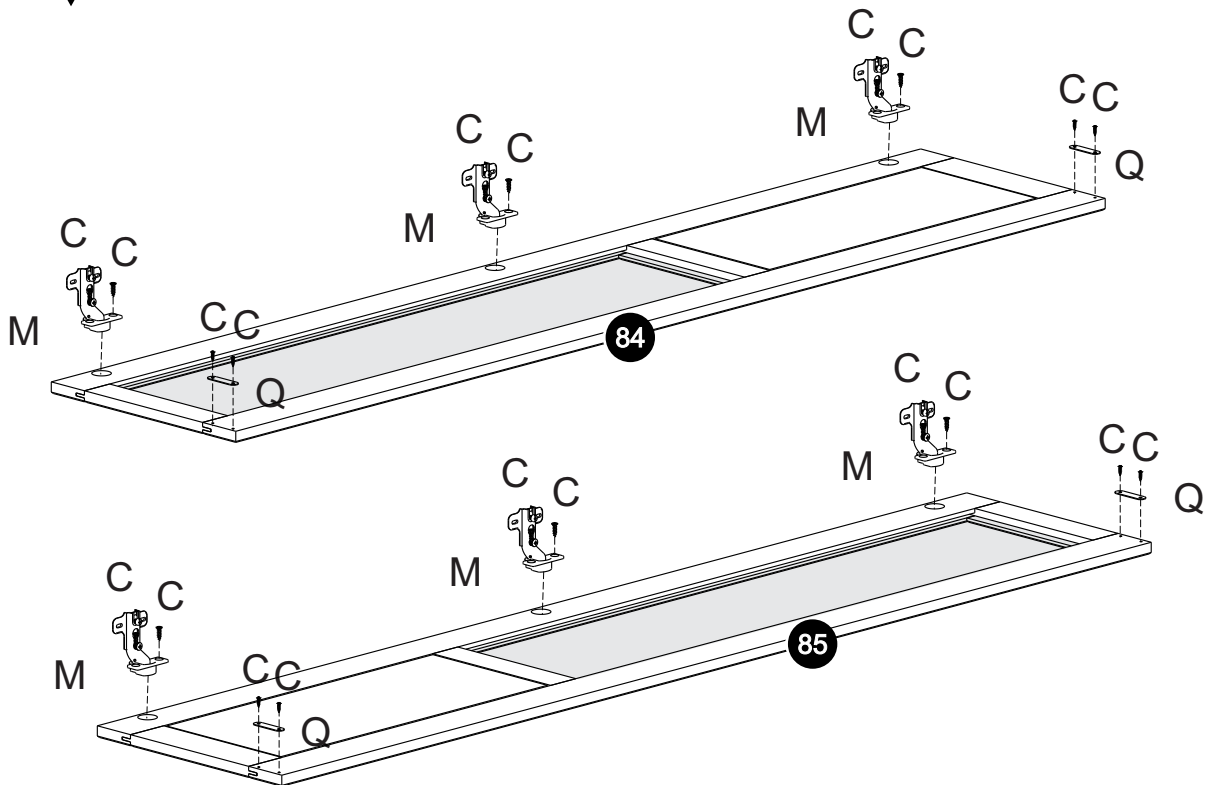
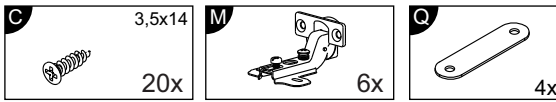

13

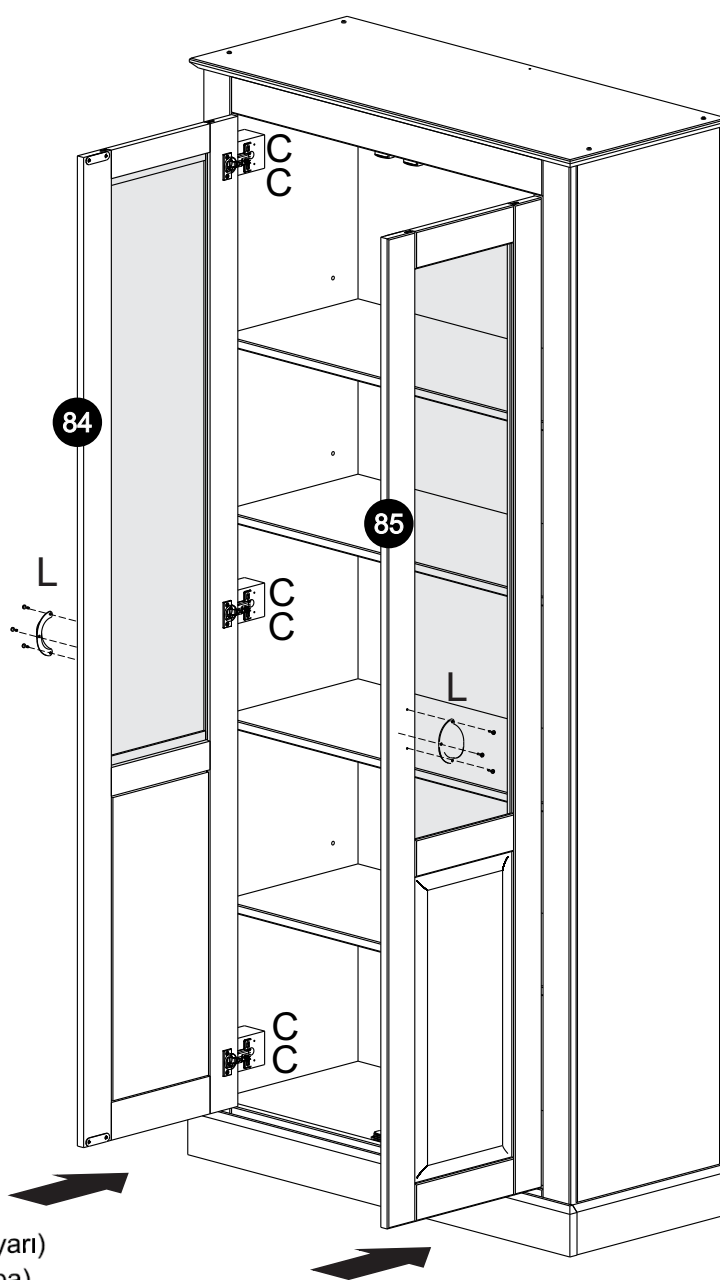
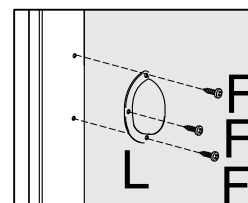
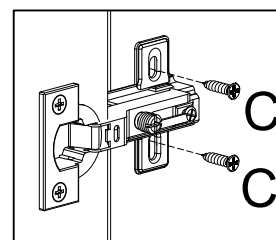
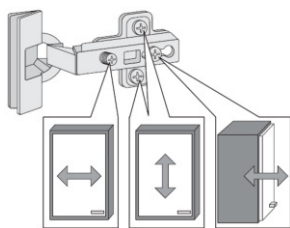
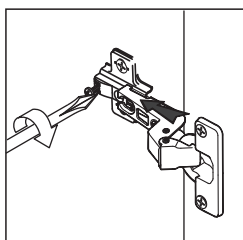
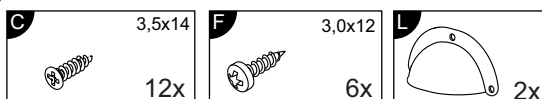

- Türen einstellen (Scharniere justieren)
- Adjusting the doors (adjusting the hinges)
- Régler les portes (ajuster les charnières)
- Sistemare le porte (regolare le cerniere)
- Deuren instellen (scharnieren afstellen)
- Nastawić drzwi (wyregulować zawiasy)
- Vyrovnejte dvířka (seříd'te závěsy)
- Nastavenie dverí (nastavenie závesov)
- Állítsa be az ajtókat (állítsa be a zsanérokat)
- Reglare ușii (ajustare balamale)
- Kapıların ayarlanması (menteşelerin seviye ayarı)
- Регулировка Дверей (регулировка шарнира)

14

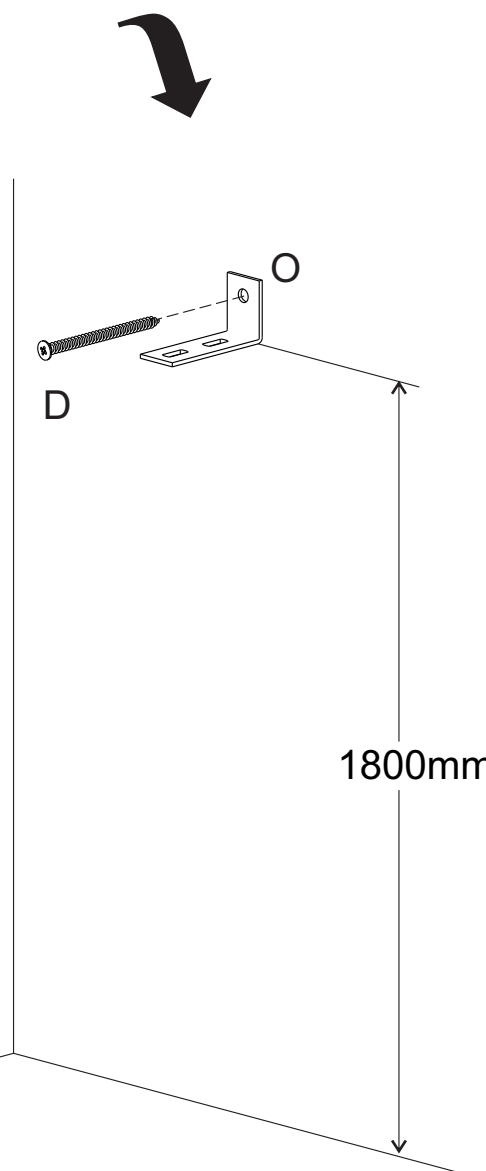
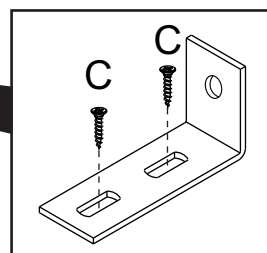
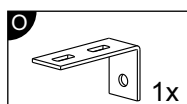
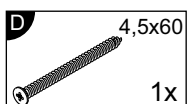
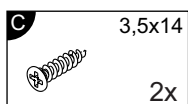

Achtung • Attention • Attenzione Opgelet • Uwaga • Pozor • Figyelem Atenție • Dikkat • Внимание	
(D)	Wandbefestigung dient als Kippschutz – unbedingt anbringen! Bei einigen Wandtypen kann ein Spezialdübel erforderlich sein!
(GB)	The wall fastening serves to prevent tipping – be absolutely sure to mount it! For certain wall types, a special wall plug may be necessary!
(FR)	La fixation murale sert de protection contre le basculement – à installer impérativement ! Pour certains types de murs il faut des chevilles spéciales !
(IT)	Il fissaggio alla parete serve da protezione anti-ribaltamento – attaccarla assolutamente! Per alcune strutture di parete può essere necessario un tassello speciale!
(NL)	Bevestiging aan de muur dient als kantelbescherming – zeker en vast bevestigen! Bij enkele muurtypes is een speciale plug misschien vereist!
(PL)	Mocowanie do ściany jest jednocześnie zabezpieczeniem przed przewróceniem – koniecznie zamontować! Do niektórych rodzajów ścian koniecznie zastosować specjalne kolki mocujące.
(CZ)	Montáž na stěnu slouží jako ochrana proti převrnutí – bezpodmienečně umístěte! U některých typů stěn může být zapotřebí speciální hmoždinka!
(SK)	Upevnenie na stenu slúži ako ochrana proti prevráteniu – bezpodmienečne použite! Pre niektoré druhy stien môže byť potrebná špeciálna hmoždinka!
(HU)	A terméket a falhoz kel rögzíténi, különben az felborulhat! Egyes faltípusoknál speciális tiplit kell használni!
(RO)	Sistemul de fixare la perete servește ca protecție la răsturnare – de montat obligatoriu! Pentru unele tipuri de pereți este posibil să fie necesar un diblu special!
(TR)	Duvardaki sabitleme, devrilmeye karşı bir emniyet tedbiridir ve mutlaka monte edilmelidir! Bazı duvar tiplerinde bunun için özel bir dübel gerekli olabilir!
(RU)	Обязательно установите крепление на стене во избежание опрокидывания! Для некоторых типов стен может потребоваться специальный дюбель!